



BillPro-CRX™ Series Card Reader

Installation & Operation Guide

INTRODUCTION

The BillPro-CRX Series Card Reader is the result of extensive research and development in computerized crediting systems. These greatly simplified systems provide important features never before available in any combo bill acceptor. The BillPro-CRX Series Card Reader extends the capability of the vending machine to generate maximum performance and profitability.

This page contains general information on installing, operating and maintaining the BillPro-CRX. Some of the many outstanding features include:

- Self-Clearing vertical swipe
- Illuminated inlets on card and bill paths
- Audible feedback for card swipe/cancel
- High contrast dual line display
- Flash programmable memory
- Metal bezel and rugged design
- Programmable acceptance of the following bills: \$1,\$5,\$10,\$20; Coupon capabilities
- Credit or debit card acceptance
- Installs easily in existing mountings
- Self-diagnostics communicated via status light
- Built upon the flexible BillPro system
- Manufactured and supported by Coinco
- Made in the U.S.A.

INSTALLATION AND OPERATION

INSTALLING THE CRX CARD READER ON A BILLPRO BILL ACCEPTOR

(for retrofit units only)

1. Verify the BillPro bill acceptor is functioning properly before installing the CRX mask.
2. Using a Phillips screwdriver, remove the three screws that secure the BillPro mask to the mounting frame. *(see figure 1)*
3. With the mask out of the way, note the position of the ground wire screwed to the mounting frame.

4. Remove the four screws that attach the mounting frame and ground spring to the main frame of the BillPro. Save the ground spring and all screws for re-assembly. *(see figure 1)*
5. Install the new mounting frame, from the CRX kit, onto the BillPro along with the ground spring removed in step 4. Use the four screws from step 4. **Be sure to attach the bill acceptor ground wire to the mounting frame.**
6. The CRX card reader harness can be routed out either side of the unit when the harness is aligned with one of the cutouts in the new mounting frame. Use the three screws removed in step 2, attach the CRX card reader mask to the BillPro mounting frame. Make sure the mask mounts flush to the mounting frame.

INSTALLING THE BILLPRO-CRX IN A VENDING MACHINE

1. Disconnect the vending machine's power.
2. Install the BillPro-CRX unit into the mounting opening of the vending machine using the appropriate hardware (not included).

NOTE: Should additional mounting hardware be required, please contact your local Coinco office or machine manufacturer.

3. To ensure proper operation, the BillPro mounting surface must be connected to the vending machine's earth ground.
4. Connect the BillPro MDB bill validator interface harness to the vending machine controller and coin changer. Ensure that the credit card transaction controller unit is properly installed for your BillPro-CRX and then connect the card reader interface harness to the appropriate port.

VERIFYING INSTALLATION

1. Restore power to the vending machine.
2. On power up the bill inlet LEDs will begin to blink and stacker motor will cycle. The card swipe status LED will blink five times with an audible beep and LCD will turn on and display "Coin Acceptors" and software version. Check LCD for the expected startup message from your transaction controller. If this sequence of events does not occur, refer to the Troubleshooting section of the Operation & Service Manual.
3. With vend price set below one dollar, swipe a valid credit card or other test card provided by backend service supplier.
4. Verify that the card reader accepted the credit card by checking for a single audible beep. The BillPro-CRX card reader will emit three beeps on an invalid card swipe or credit card.
5. Verify that credit has been established with the machine.
6. After credit has been established, press the cancel credit button on the card reader. This should also be accompanied by an audible beep.
7. Verify the machine credit has been canceled.

NOTE: Please refer to the BillPro Bill Acceptor Operation and Service Manual for detailed information on the BillPro Bill Acceptor.

CLEANING

The BillPro-CRX card reader is manufactured from metal and high-quality plastics, which should only be cleaned with a soft bristle brush or cloth dampened with warm water and mild detergent solution, if necessary. Dust can be removed using a soft brush or blown out using compressed air.

PROCEDURE

1. Disconnect the power before cleaning.
2. Mix warm water and mild detergent.
3. Dampen the brush or cloth with solution and wipe the outside of the card reader.
4. Rinse the cloth with clean water and wipe the previously cleaned area again to rinse off solution.

5. To clean the card slot, dampen a cloth with the detergent solution and pull the towel through the card slot.
6. Wait until the unit is completely dry to restore power and verify the unit is functioning properly.

WARNING: Never submerge the unit in water and avoid getting water on the circuit board of the reader. Do not use petroleum-based cleaners, solvents, steel wool, scouring pads, or stiff bristle brushes for cleaning. Do not spray any type of lubricant on any part of the card reader or BillPro.

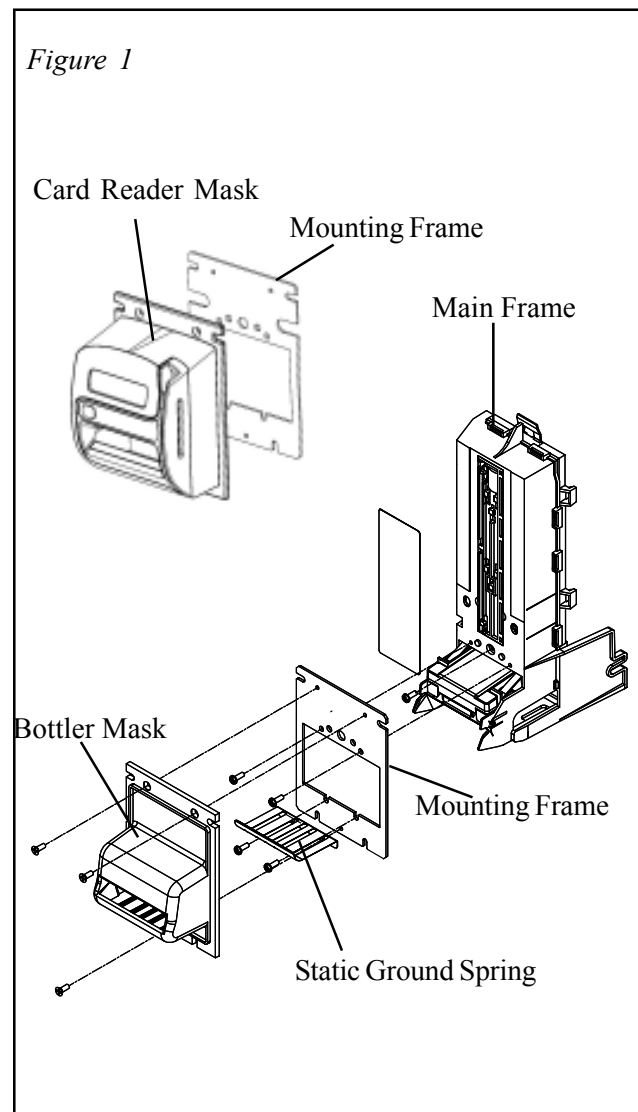

Coin Acceptors Inc. 300 Hunter Ave, St. Louis, MO 63124
Phone: 800.325.2646
email: techsupport@coinco.com
website: www.coinco.com

Coinco Publication No. 926111 Rev 1
01/2006 Printed in the U.S.A.